

Description

Front Panel

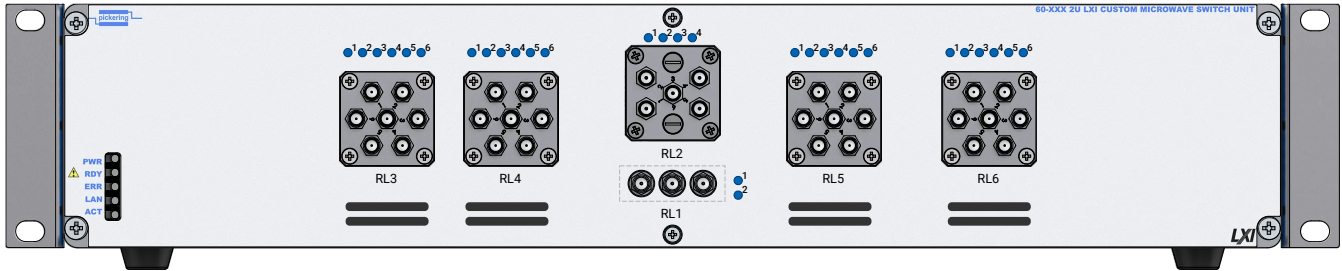

Schema

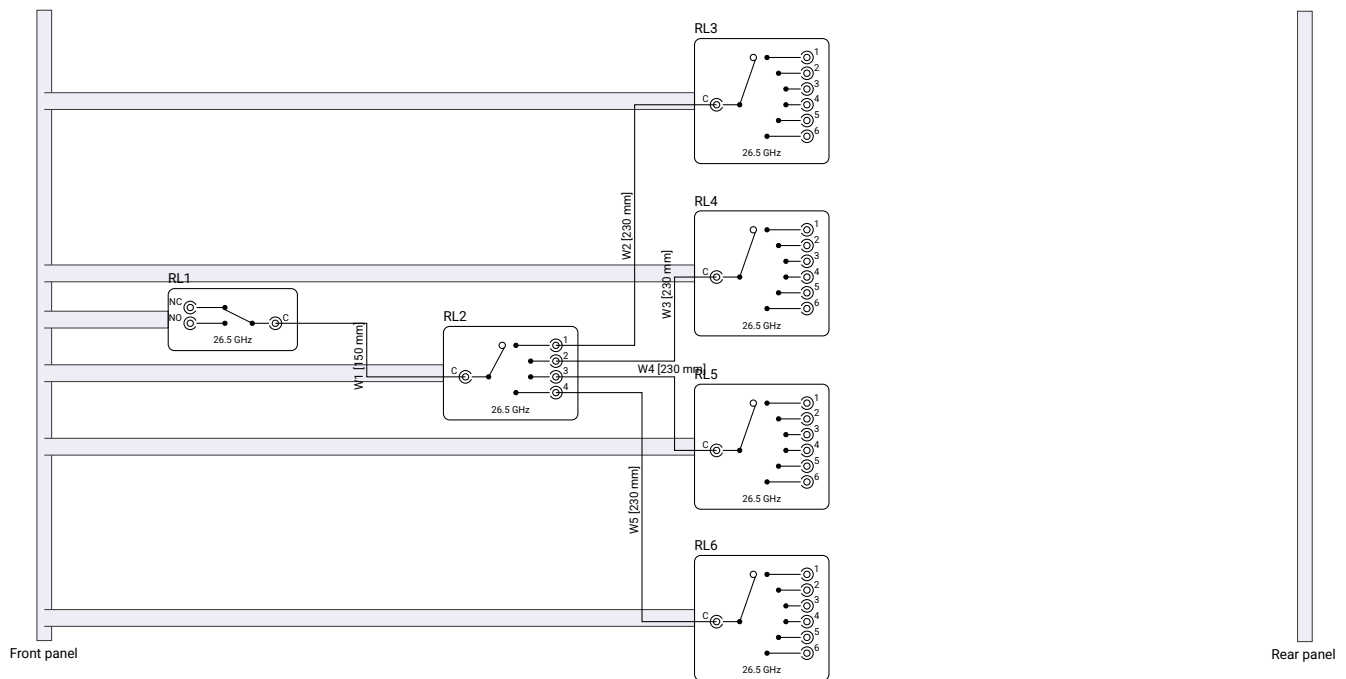

Quantity of pieces of the designed assembly: 1x (2U LXI Box)

Front Panel Relays

Label	Part Number	Frequency	Conn. type	Format	Remote	Left (mm)	Top (mm)
RL3	R591-702-600	26.5 GHz	SMA	SP6T	no	120.7	24.3
RL4	R591-702-600	26.5 GHz	SMA	SP6T	no	165.5	24.3
RL2	R591-702-400	26.5 GHz	SMA	SP4T	no	223.7	14.7
RL1	R570-F12-000	26.5 GHz	SMA	SPDT	no	222	58.7
RL5	R591-702-600	26.5 GHz	SMA	SP6T	no	282.3	24.3
RL6	R591-702-600	26.5 GHz	SMA	SP6T	no	338.2	24.3

Cables

Label	From (port) - to (port)	Part Number	Frequency	Conn. type	Length (mm)
W2	RL2 (1) - RL3 (C)	C589-086-09	26	SMA	230

Label	From (port) - to (port)	Part Number	Frequency	Conn. type	Length (mm)
W3	RL2 (2) - RL4 (C)	C589-086-09	26	SMA	230
W4	RL2 (3) - RL5 (C)	C589-086-09	26	SMA	230
W5	RL2 (4) - RL6 (C)	C589-086-09	26	SMA	230
W1	RL1 (C) - RL2 (C)	C589-086-06	26	SMA	150

Based on the attached customer specific microwave assembly documentation we confirm the design correctness, freeze of the design, and approve the production of the microwave assembly

Responsible technician:

Reviewed and approved by:

_____ . date _____